

DIMENSIONS/TECHNICAL DATA

AME 3030

Critical Dimension	Perspective drawing	Tolerance grade not noted	Basic size	$0 < a \leq 120(4.72")$	$120(4.72") < a$	Note the Angle tolerance
Most important dimensions			Tol Value	$\pm 1.27(0.05")$	$\pm 2.54(0.1")$	$\pm 1^\circ$

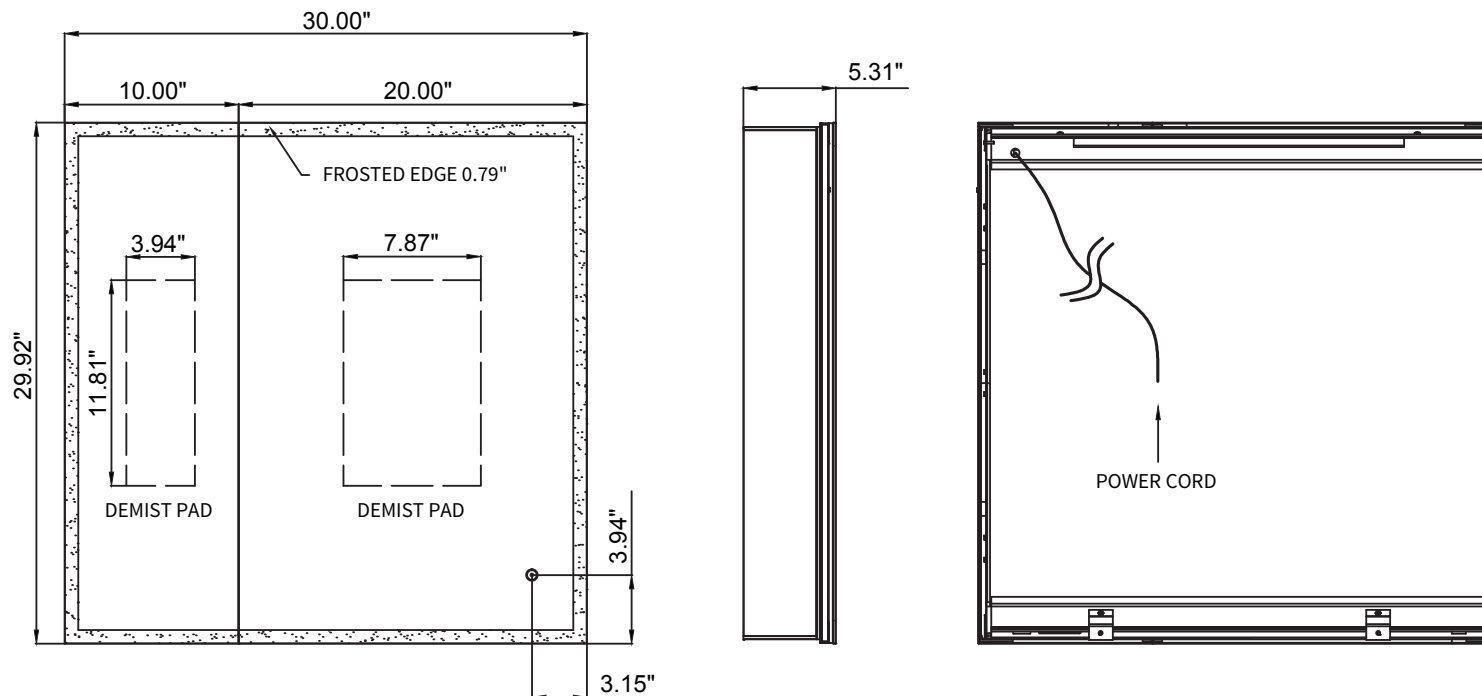

- Surface or Recessed mount double door mirror cabinet without bottom light, top light inside of the cabinets , one door is 10", another door is 20"
- Door type: Mirror+Aluminum+Mirror
- Aluminium frame
- Back-lit 2835 LED strip, 120 beans,14w/meter
- Shelves: 3pcs adjustable tempered glass shelves
- 3 soft close hinges (non-bridge)
- Touch sensor with dimmable (3000K+/-300K)
- Mirror kit instead of Aluminum kit for side when surface mounted
- power socekt 1pcs as picture
- demist (1 pcs *size 100*300mm +1pcs 200*300)
- electric wire will be made by the way as picture

ATTENTION! Dimensions may vary by up to 3/8". It is highly recommended to pull all dimensions of actual model for installation and measuring purposes.